



Smart Agriculture With IOT: Innovations in Crop Monitoring and Yield Prediction

Jayagopi G¹ and Sumathi C B²

¹Department of Computer Science and Engineering, Mother Theresa Institute of Engineering and Technology, Palamar, India

²PG and Research Department of Mathematics, Marudhar Kesari Jain College for Women, Tamil Nadu, India

Abstract: The Smart Crop Monitoring System, powered by the Internet of Things (IoT), is a cutting-edge approach to modern agriculture designed to maximize resource efficiency and improve crop management. By integrating advanced technologies such as sensors, IoT devices, cloud computing, and automation, this system enables real-time monitoring and control of crop health and environmental conditions. Key components, such as soil moisture, temperature, humidity, light, pH, and nutrient sensors, collect critical field data. This data is transmitted wirelessly to a cloud platform, where advanced algorithms and machine learning models process and analyze it to generate actionable insights. These insights help optimize resource utilization, enhance crop productivity, and promote sustainable farming practices. Despite its benefits, the system faces challenges like high initial setup costs, data management complexities, and ensuring reliable connectivity in remote areas. Nevertheless, the IoT-enabled Smart Crop Monitoring System represents a major breakthrough in agricultural technology, offering an effective, scalable solution to modern farming challenges.

Keywords: Internet of Things (IoT), Sensors, Cloud Computing, Machine Learning, Agricultural Technology.

I. INTRODUCTION

Agriculture is fundamental to societal progress, providing the essential resources needed for survival and growth. However, traditional farming faces significant challenges, including inefficient resource use, environmental harm, and rising food prices due to the growing global population. In response to these challenges, the integration of technology in agriculture has become increasingly crucial. One such innovation is the Smart Crop Monitoring System using the Internet of Things (IoT), which offers a modern, sustainable solution to boost agricultural productivity and address environmental concerns. Agriculture is a fundamental pillar of societal development, providing the essential resources for both survival and growth. However, traditional farming practices face several challenges, including inefficient resource utilization, negative environmental impacts, and rising food prices due to the expanding global population. To address these challenges, the integration of technology in agriculture has become crucial. The Smart Crop Monitoring System, powered by the Internet of Things (IoT), represents one such technological breakthrough, offering a modern approach to enhance agricultural sustainability and productivity.

The Smart Crop Monitoring System employs a network of interconnected sensors and devices to collect real-time data on key soil and environmental conditions, including pH levels, nutrient content, light intensity, temperature, humidity, and soil moisture. By continuously tracking these factors, the system offers farmers detailed and accurate insights into their crops' health and specific needs. The sensor data is transmitted wirelessly to a cloud-based platform where it is processed, stored, and analyzed. Using sophisticated algorithms and machine learning models, the system generates valuable insights and recommendations for effective crop management. This empowers farmers to reduce resource waste and make informed decisions regarding pest control, fertilization, and irrigation. An essential aspect of the Smart Crop Monitoring System is automation. Fertilizer dispensers and automated irrigation systems can be programmed to adjust in real-time based on data, ensuring crops receive the correct amount of water and nutrients precisely when needed. This reduces labor costs, conserves resources, and boosts both crop yield and quality. The IoT-powered smart agriculture monitoring system is depicted in Fig. 1 below [12]. One further important component of the Smart Crop Monitoring System is automation. It is possible to program fertilizer dispensers and automated irrigation systems to react to real-time data,



ensuring that crops get the proper amount of nutrients and water at the right time. This lowers labour expenses and conserves resources while also increasing agricultural output and quality. The scenario of an IOT- powered smart agriculture monitoring system is shown in Fig. 1 below [12].

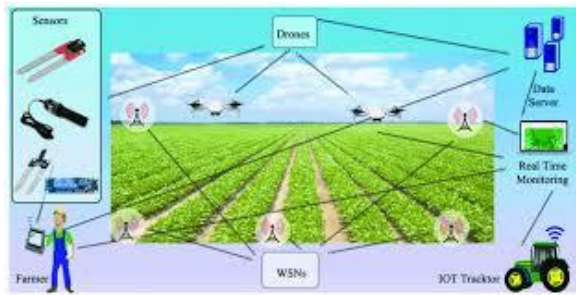

Fig. 1. IOT based small agriculture monitoring.

The integration of IoT in agriculture marks a transformative shift toward precision farming, where data-driven decision-making enhances sustainability and operational efficiency. However, adopting such systems comes with significant challenges, including high initial setup costs, the complexities of managing large volumes of data, and ensuring reliable connectivity in remote areas. This study explores the components, benefits, challenges, and potential of an Internet of Things (IoT)-based Smart Crop Monitoring System. By leveraging advanced technology, this approach aims to revolutionize traditional farming practices, address the critical needs of modern agriculture, and establish a foundation for a more sustainable future. The structure of the paper is as follows: Section 2 provides the contextual background. Section 3 discusses the system's implementation, covering the methodology, system design, and an overview of the approach. This section also introduces two key algorithms:

- (i) Harvesting and transplanting time forecasting.
- (ii) Crop data generation.

Section 4 presents the data mining research and analysis related to crop cultivation. Section 5 concludes with the study's findings and outlines directions for future research. This structured approach offers a comprehensive examination of IoT's role in advancing agricultural practices.

II. RELATED WORKS

In recent years, the application of Internet of Things (IoT) technologies in agriculture, particularly in crop monitoring systems, has garnered significant attention. This literature review examines the current state of research and

development in IoT-based smart crop monitoring systems, highlighting key findings, innovative approaches, and advancements in technology shaping this transformative field. Agriculture is one of the many sectors revolutionized by IoT technology. By employing a network of interconnected sensors and devices, IoT enables the collection of real-time data, providing valuable insights to optimize agricultural practices. Zhang et al. (2019) highlight several IoT applications in agriculture, including precision farming, livestock monitoring, greenhouse automation, and crop monitoring, all aimed at enhancing productivity and promoting sustainability. Sensor technologies form the backbone of IoT-based crop monitoring systems, with various types of sensors playing critical roles in agricultural applications. Research has extensively explored the use of these sensors. For instance, Kim et al. (2018) emphasizes the importance of soil moisture sensors, which provide crucial data on soil water content, facilitating precise irrigation scheduling. Similarly, Singh et al. (2020) highlights the role of temperature and humidity sensors in tracking microclimatic conditions vital for maintaining crop health and optimizing productivity. Additionally, Patil and Kale (2016) point out the frequent use of light sensors to measure sunlight exposure and pH sensors to monitor soil acidity, both of which are essential for effective crop management.

A critical component of IoT systems is the transmission of data from sensors to a centralized platform. Various wireless communication technologies are employed for this purpose, including cellular networks, Wi-Fi, LoRa, and Zigbee. According to Rahman et al. (2021), LoRa stands out as particularly advantageous for rural agricultural areas due to its extensive coverage and low power consumption, making it an ideal choice for long-range communication in such settings. To derive meaningful insights, sensor data must undergo processing and analysis. Cloud computing platforms such as AWS IoT and Microsoft Azure IoT are widely used for data storage and processing. Machine learning algorithms play a vital role in interpreting data and making predictions. For instance, Chlingaryan et al. (2018) demonstrated the application of machine learning models to predict crop yields by analyzing environmental and soil data, enabling more informed decision-making in agriculture. [4] analyzed that the reason that every family member will be employed and busy, the health monitoring of elderly people and patients has become very crucial. In the proposed methodology caretakers can get the information of the temperature and the pulse rate of the people being monitored at home.



In agricultural monitoring systems, automation involves the use of actuators to perform tasks such as irrigation and fertilization based on sensor data. Ayaz et al. (2019) found that automated irrigation systems have notably reduced water consumption while boosting crop yields. Additionally, fertilizer dispensers equipped with nutrient sensors help optimize the application of fertilizers, ensuring that crops receive the right nutrients in the correct quantities, thereby minimizing waste and improving efficiency. The value of IoT-based agricultural monitoring systems has been demonstrated through several case studies. In a study by Ramesh & Karthick (2017), the installation of a smart irrigation system in a paddy field resulted in a 20% improvement in water use efficiency and a 15% increase in crop yield. Similarly, Pawar et al. (2020) explored a greenhouse environment where the integration of automation technologies and IoT sensors enhanced climate control, leading to increased crop productivity. These case studies highlight the significant benefits of IoT in optimizing agricultural practices and improving overall efficiency. Despite the potential benefits of IoT-based agricultural monitoring systems, there are several challenges that hinder their widespread adoption. Key obstacles include high initial setup costs, the complexity of data management, and ensuring reliable connectivity in remote areas. Gao et al. (2022) suggest that future research should focus on developing cost-effective sensor technologies, enhancing data security, and exploring the role of edge computing in reducing bandwidth requirements and minimizing data transmission delays. These advancements could help overcome the barriers to implementing IoT systems in agriculture. Precision agriculture (PA), as introduced by Nagaraja et al. (2023), represents the next frontier in smart farming technology. This paper introduces a lightweight communication protocol designed to strike an optimal balance between energy efficiency and robust security, which are critical for the success of PA. Unlike previous approaches, the study proposes a synchronized architecture that employs unique public-key encryption to ensure that only authorized on-field sensors can participate in the PA system. The proposed logic is implemented and tested in MATLAB using a suitable PA environment and a standardized testbed for comparative assessment. [2] discussed that Smart wearables are redefining the way

people move and behave in real-time. Workers will be alerted to the presence of toxic gases as well as be tracked in the event of an accident if this system is implemented. Additionally, the instrument has sensors for methane and carbon monoxide gases included in its design. The prototype can detect gas in the air, the rate of the miner's breathing, the change in temperature and humidity, and the miner's location at all times.

Laxmi C. et al. (2017) proposed a model that utilizes sensors in cultivated fields to monitor key soil parameters such as humidity, temperature, sunlight, and the concentrations of nitrogen (N), phosphorus (P), and potassium (K). By analyzing these factors, farmers can identify nutrient deficiencies and enhance soil productivity. In a similar vein, Apurva C. et al. (2016) focused on the application of wireless sensor networks (WSNs) for real-time agricultural field monitoring. Their study highlights how the stagnation in agricultural yield rates has driven the need for new monitoring solutions to improve agricultural practices.

Chandan Kumar Sahu et al. (2015) proposed a model for supervised and controlled water flow and direction in agriculture. The system utilizes a soil moisture sensor and the DHT11 sensor for monitoring environmental conditions. It also includes a feature for determining the direction of the water flow, which is then communicated to the farmer's phone and Gmail account. With this model, the farmer can easily control the irrigation system by turning the motor on or off with just a single click, enhancing convenience and efficiency in water management.

III. THE PROPOSED FRAMEWORK

An Internet of Things (IoT) system is built around key components: sensors, processors, and applications. The proposed model in this work demonstrates how these components are interconnected, as illustrated in the block diagram shown in Fig. 3.1. In this system, the microcontroller interfaces with the sensors to collect data, which is then displayed on the user's mobile app. This app provides farmers with real-time sensor data, allowing them to make timely decisions and take appropriate actions to address the soil's needs, enhancing efficiency in agricultural management.

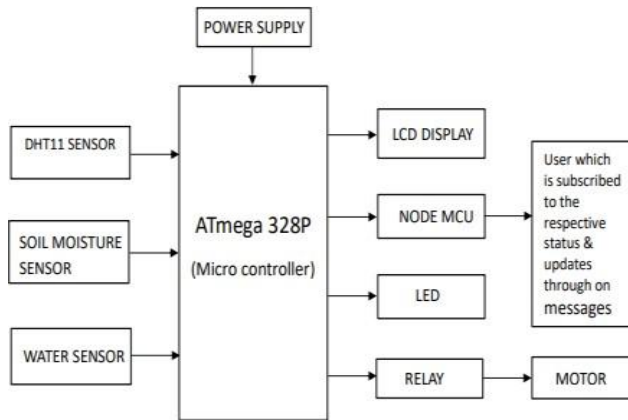

Fig. 3.1: Proposed Block diagram

The methodology for developing a Smart Crop Monitoring System using IoT encompasses several crucial steps, each aimed at ensuring the system's efficiency and effectiveness in agricultural management. Below is a detailed description of the methodology:

1.Sensor Selection:

The first step involves choosing the appropriate sensors to collect data on various parameters such as soil moisture, temperature, humidity, light intensity, pH levels, and nutrient content. The sensors should be chosen based on their accuracy, durability, and compatibility with the system.

2.System Design:

The system architecture is designed to integrate the selected sensors with a microcontroller. This design ensures that the sensors can accurately capture and transmit data to a central platform. The system also includes the design of an automated irrigation system, if applicable, and a user interface (such as a mobile app) for real-time data visualization.

3.Data Collection:

The sensors collect real-time data from the agricultural field, such as soil moisture, temperature, and other relevant environmental factors. The data collection process should be continuous to ensure timely insights into the condition of the crops and soil.

4.Data Transmission:

The collected data is transmitted wirelessly from the sensors to a central platform or cloud-based server. Wireless communication technologies such as Wi-Fi, LoRa, or Zigbee are used to transfer the data from the field to the server, ensuring efficient and reliable transmission over long distances.

5.Data Processing:

The transmitted data is then processed using cloud computing or edge computing platforms. The data is analysed to generate insights, such as detecting soil deficiencies, forecasting irrigation needs, or predicting crop yield. Machine learning models can be employed to provide more accurate predictions and recommendations based on historical data and real-time input.

6.Automation:

Based on the processed data, the system can automatically perform actions like controlling irrigation systems, adjusting environmental conditions in greenhouses, or notifying farmers of potential issues. For example, if soil moisture levels are low, the irrigation system may be triggered automatically to water the crops, optimizing resource use.

By following this methodology, the IoT-based Smart Crop Monitoring System can provide farmers with the tools to make data-driven decisions, optimize agricultural practices, and enhance crop productivity and sustainability.

The following Fig. 3.2 illustrates the smart crop monitoring cycle for farming applications.

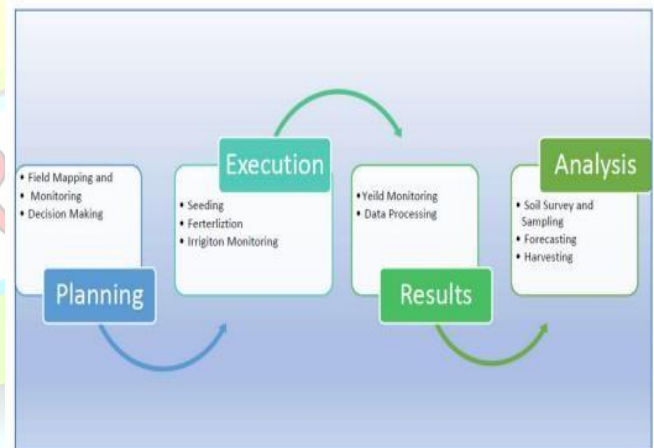

Fig. 3.2: Smart crop monitoring cycle

3.3 BENEFITS

- **Resource Optimization:** The system ensures efficient use of resources like water and fertilizers by providing real-time data, enabling precise application based on crop needs and soil conditions.
- **Enhanced Crop Yields:** Continuous monitoring of crop health and environmental conditions helps identify issues early, leading to improved crop care and, ultimately, higher productivity.



- **Cost Savings:** Automation reduces the need for manual labour and lowers input costs by optimizing irrigation schedules and fertilizer usage, leading to significant savings.
- **Sustainability:** The system promotes environmentally friendly practices by minimizing waste and using resources efficiently, contributing to sustainable farming.
- **Increased Efficiency:** Automated systems streamline farming operations, reduce human error, and increase the precision of tasks like irrigation and nutrient management, resulting in more efficient farming practices.

3.3 Applications

Smart crop monitoring systems, leveraging IoT technology, have found applications ranging from small-scale farming activities—such as weeding, crop protection, and local pest management—to large-scale initiatives like global remote sensing surveys of grasslands, forests, and farmland. These systems enhance efficiency and sustainability in agriculture.

The key applications of a smart crop monitoring system, as illustrated in Fig. 3.2, include:

- Real-time Monitoring
- Automated Irrigation Systems
- Pest and Disease Detection
- Nutrient Monitoring
- Weather Forecasting and Climate Monitoring
- Crop Health Monitoring
- Data Analytics and Decision Support
- Supply Chain Management



Fig. 3.2: Applications of a smart crop monitoring

IV. RESULTS

The integration of IoT into smart crop monitoring transforms traditional farming into a more efficient, productive, and sustainable practice. By leveraging data and technology, these systems address the increasing demands of the global population while optimizing resource utilization. The following testbed results illustrate the efficiency of an IoT-based crop monitoring system, with tests conducted under various conditions, including wet and dry soil, temperature, humidity, and water level monitoring.

SOIL SENSOR

The Fig. 4.1 and 4.2 shows the soil is wet and the soil is dry.



Fig. 4.1: Wet soil test

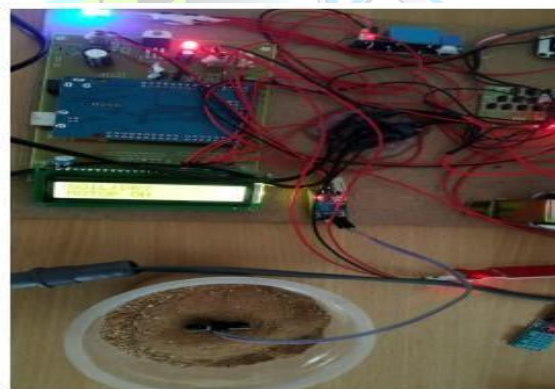

Fig. 4.2: Dry soil test



MONITORING

The Fig. 4.3 shows the IoT Based Soil Nutrient Monitoring & Analysis systems the farmer will be able to monitor soil moisture, soil temperature, and soil nutrient content like Nitrogen, Phosphorous & Potassium. The farmer can monitor all these parameters wirelessly on a mobile phone or the PC System.

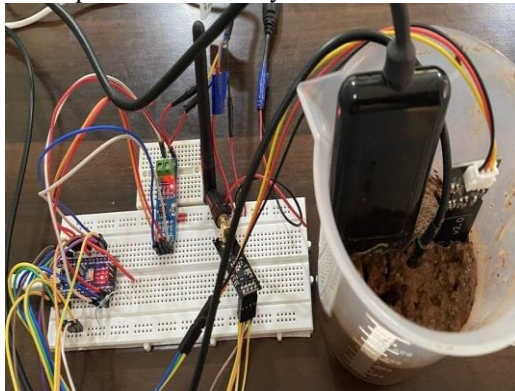

Fig. 4.3: moisture, temperature, soil nitrogen phosphorous & potassium



Fig. 4.4: Water level monitoring
 The Fig. 4.4 shows the 3 In 1 Soil Test Kit PH Meter

V. CONCLUSION

The Internet of Things (IoT) is applied to the agriculture industry through the proposed methodology, aiming to optimize crop production by predicting the ideal crop sequence for specific soil types. Using Thing Speak, real-time soil sampling is facilitated, enabling the use of collected data for crop analysis. Measurements of environmental factors such as temperature, humidity, and soil moisture are taken at various times and on different days. This data allows farmers to leverage cloud-based

insights to improve productivity, assess fertilizers, and detect field diseases. The technology is practical and cost-effective, emphasizing efficient water resource management to promote sustainability and tackle challenges like water scarcity. The adoption of smart crop monitoring systems powered by IoT marks a transformative shift in agriculture, paving the way for a more efficient, productive, and sustainable farming future. As technological advancements continue, these systems will become more accessible and effective, enhancing the capacity to feed the global population while conserving natural resources.

REFERENCES

1. Nagaraja, G. S., Vanishree, K., and Azam, F. "Novel Framework for Secure Data Aggregation in Precision Agriculture with Extensive Energy Efficiency." *Journal of Computer Networks and Communications*,
2. Christo Ananth, B.Sri Revathi, I. Poonguzhali, A. Anitha, and T. Ananth Kumar, "Wearable Smart Jacket for Coal Miners Using IoT", 2022 2nd International Conference on Technological Advancements in Computational Sciences (ICTACS), 2022, pp. 669-672,
3. Rehman, A.; Saba, T.; Kashif, M.; Fati, S.M.; Bahaj, S.A.; Chaudhry H. A Revisit of Internet of Things Technologies for Monitoring and Control Strategies in Smart Agriculture. *Agronomy* 2022, 12,127.
4. Christo Ananth, Anand Nayyar, Bandana Mahapatra, "Analysis of IoT Based Weather Monitoring using Fuzzy Logic", Patent number: 1189027, Canadian Patent, 4th January 2022.
5. Ayaz, M., Ammad-Uddin, M., Sharif, Z., Mansour, A., and Aggoune, E. H. M. "Internet-of- Things (IoT)-Based Smart Agriculture: Toward Making the Fields Talk." *IEEE Access*, vol. 7, 2019,pp.129551-129583
6. Chlingaryan, A., Sukkarieh, S., and Whelan, B. "Machine Learning Approaches for Crop Yield Prediction and Nitrogen Status Estimation in Precision Agriculture: A Review." *Computers and Electronics in Agriculture*, vol. 151, 2018, pp. 61-69,
7. Ramesh, A., and Karthick, S. "Design and Implementation of a Smart Irrigation System Using IoT." *International Journal of Advanced Research in Computer Science and Software Engineering*, vol. 7, no. 12, 2017, pp. 5-10.
8. Laxmi C. Gavade, A.D Bhoi , "N, P, K Detection and



Control for Agriculture Applications using PIC Controller”, International Research Journal of Engineering and Technology (IRJET). Volume: 6 Issue: 4 | April 2017

9. Apurva C. Pusatkar, Vijay S. Gulhane, “Implementation of Wireless Sensor Network for Real Time Monitoring of Agriculture”, International Research Journal of Engineering and Technology (IRJET). Volume: 03 issue: 05 | May-2016.

