

A Four Quadrant Speed Control BLDC Motor Using GA Optimized PID Controller and SVPWM

AKHIL M K,

Post Graduate Student, M.E Power Electronics and Drives,
LIT- Chennai/Anna University, Tamilnadu, India.
akhilemke@hotmail.com

J. ANTONY ROBINSON,

Assistant Professor, M.E Power Electronics and Drives,
LIT- Chennai/Anna University, Tamilnadu, India.

Abstract—Brushless DC Motors, by their high efficiency, high torque and low volume are extensively used in many industrial applications. By taking it into consideration, a complete model of four quadrant control of BLDC Motor operation in association with GA optimized PID controller for its position control to obtain maximum speed operation is presented in this paper. The power supply to feed the windings of the motor is given by an inverter circuit. The gate drives to the switches of inverter is fed by space vector PWM technique in this paper for reducing the total harmonic index of the proposed system than the conventional existing methods. The MatLab/ Simulink is used in this paper to establish a model of four quadrant operation of BLDC motor.

Index Terms—Brushless DC Motor, GA optimized PID controller, Space Vector PWM.

I. INTRODUCTION

BRUSHLESS DC MOTORS are becoming more popular in industrial applications which require high performance as they are having comparatively high starting torque, smaller volume and simple system structure compared to induction motors used commonly in industries. The motor has less inertia and therefore it is easier to start and stop.

BLDC motor has a permanent magnet rotor and laminated stator poles to carry windings. Currently, design of the BLDC Motor drive involves some complex processes such as modelling, control scheme selection, simulation, parameters tuning etc. To get optimal performance expert knowledge of system is required for tuning the controller parameters of servo system. Recently, in the existing system different modern control solutions included the use of PI controllers for the optimal control design of four quadrant operation of BLDC Motor. However, these methods are complex in nature and require excessive computation. In addition to that, driver circuit is required to provide gate pulses to the inverter. In the existing systems the driver

circuit to the inverter switches was providing multiple synchronized Pulse Width Modulation signals to the inverter. Providing rectangular or trapezoidal voltage strokes supply to the BLDC motor.

In a BLDC motor the brushes and commutator have been eliminated and the windings are connected to the control electronics. The control electronics, which includes the inverter supply and the driver circuit for inverter switches, replaces the function of the commutator and energizes the proper winding. So an inverter supplies power to the stator windings of the BLDC Motor. The switches of the inverter require gate supply which is provided by the driver circuit. By providing the most advanced pulse width modulation technique of Space Vector PWM technique to the gate driver circuits the harmonics in the inverter output is reduced to much extent.

Observations showed that PID controller provides a simple and yet effective solution to many control problems in closed loop control systems. Even though PID controllers have a simple structure, it is a quite challenging task to find the optimized PID gains to provide the best possible output. Continuing performance improvements of computational systems are required for obtaining best performance output. This requirement has made Genetic Algorithm (GA) the most appropriate technique for finding global optimal solution for some of the control systems operations such as the search of optimal PID controller parameters.

II. OPERATING STRATEGY OF PROPOSED SYSTEM

The proposed system has the speed control in association with four quadrant operation of Brushless DC motor. For the operation of BLDC motor, it requires a three phase AC supply to be feed with the help of an inverter. It provides a AC supply voltage to the windings of BLDC motor. The inverter has six switches to convert the DC supply to three phase AC supply. The gate drive circuit is given to supply the gate supply to the switches of the inverter. The gate drive circuit can control the operation of BLDC

motor.Space Vector PWM signals are provided by gate driver circuit to the switches of inverter. The implementation of Space Vector PWM reduces the total harmonic distortion of the inverter operation output voltage.

The closed loop speed control of BLDC motor is performed with the help of PID controller.The PID controller in association with the global optimization technique of genetic algorithm is used in this paper. The speed of BLDC motor is sensed and the necessary signals are provided by hall position sensors to the PID controller. The PID controller in association with Genetic Algorithm provides the output for obtaining best controlled speed to the gate driver circuits which works based on Space Vector PWM. The gate driver circuit provides the gate supply and thus a controlled output is provided to the stator windings of BLDC motor. Thus the speed of BLDC motor can be controlled and the process continues until the supply voltage turns to OFF state.

The process is followed for the operation of the BLDC motor in all the four quadrants. The four quadrant operating modes are Forward Motoring, Forward Braking, Reverse Motoring and Reverse Braking. In regenerative mode of operation the supply is used to charge the battery with the regenerative power. The overall architecture of the proposed system is shown in the fig.1.

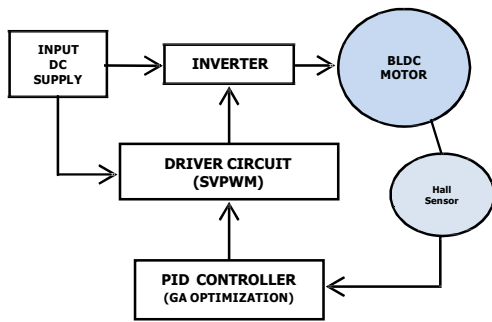

Fig.1.Overall architecture of the proposed system.

A. BLDC Motor

BLDC motors are generally powered by a conventional three-phase voltage source inverter (VSI) or current source inverter (CSI) which is controlled using rotor position. The rotor position can be sensed using Hall position sensors, resolvers, or optical encoders. Due to ease of control in BLDC motors, they are preferred for numerous applications in low power and variable speed drives. BLDC motor drive and it is also called a trapezoidal brushless DC drive, or rectangular fed drive. It is supplied by three-phase rectangular current blocks of 120° duration, in which the ideal motional EMF is trapezoidal, with the constant part of the waveform timed to coincide with the intervals of constant phase current.

The PMBLDC motor has its losses mainly in the stator due to its construction; hence the heat can easily be dissipated into the atmosphere. As the back EMF is directly proportional to the motor speed and the developed torque is almost directly proportional to the phase current, the torque can be maintained constant by a stable stator current in a BLDC motor. The average torque produced is high with fewer ripples in BLDC motors. BLDC motor can be used in general and low cost applications. These motors are preferred for numerous applications, due to their features of high efficiency, silent operation, compact in size and low maintenance.

The stator of a PMBLDC motor usually has three phase concentrated windings; however, the rotor construction varies according to desired requirements. Two main configurations of PM rotors are surface mounted magnet type where magnets are mounted on the outer surface of the rotor, and the buried magnet type where the magnets are mounted inside the magnetic structure of the rotor.

Another type of PMBL motor is the axial field machine where the direction of the magnetic field is axial instead of radial. The configurations of axial field BLDC motors include a single stator and single rotor, a single stator sandwiched between two rotors (double air gaps), a single rotor sandwiched between two stators (double air gaps) and a variety of multiple stators and rotors (multiple air gaps).

Any of these BLDC motor rotor configurations can be selected on the basis of application and power rating. Various other configurations of BLDC machines include Axial Flux Permanent Magnet (AFPM) machines, Permanent Magnet alternators and torous alternators with different rotor geometries like surface type, interior type, radial and axial field machines in two, three and multiphase PMBLDC machines.

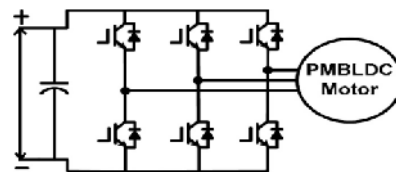

Fig.2. Conventional VSI based PMBLDC Motor drive.

A BLDC motor can be divided into electrical part and mechanical part. The electrical part contains phase currents, phase voltages and back-EMF voltages, while the mechanical one is described by electromagnetic torque, load, motor inertia, angular speed and rotor position. Equation (1) shows the relation between electrical parameters.

$$\begin{pmatrix} V_b \\ V_c \end{pmatrix} = \begin{pmatrix} R_s & 0 & 0 \\ 0 & R_s & 0 \\ 0 & 0 & R_s \end{pmatrix} \begin{pmatrix} i_a \\ i_b \\ i_c \end{pmatrix} + \frac{d}{dt} \begin{pmatrix} L & M & M \\ M & L & M \\ M & M & L \end{pmatrix} \begin{pmatrix} i_a \\ i_b \\ i_c \end{pmatrix} + \begin{pmatrix} e_a \\ e_b \\ e_c \end{pmatrix} \quad (1)$$

where V_s is the phase voltage, R_s is the phase resistance, i_s is the phase current, L is the self-inductance, M is the mutual

inductance and e_s is the back-EMF voltage. The relations describing the mechanical activity in the

motor are presented in equations(2) and (3).

$$T_e = \frac{g(e_a i_a + e_b i_b + e_c i_c)}{g \, dt} = \frac{J \, d m_r}{dt} = T_e - T_1 \quad (2)$$

where T_e is the electromagnetic torque, T_1 is the load torque,

p is the pole pair number, m_r is the mechanical speed in electric terms and J is the motor inertia. Fig.2 shows a conventional voltage source inverter fed Permanent Magnet BLDC motor drive.

B. PID Controller In the absence of knowledge of the underlying process, a PID controller has historically been considered to be the best controller.

As shown in fig.2. is a typical inverter drive system for a BLDC motor. The switches used are IGBT. Typical waveforms for a BLDC motor with trapezoidal flux distribution are shown in fig.3. Approximately, the back EMF is constant for 120° , before and after which it changes linearly with rotor angle. In order to get constant output power and consequently constant output torque, current is driven through a motor winding during the flat portion of the back EMF waveform.

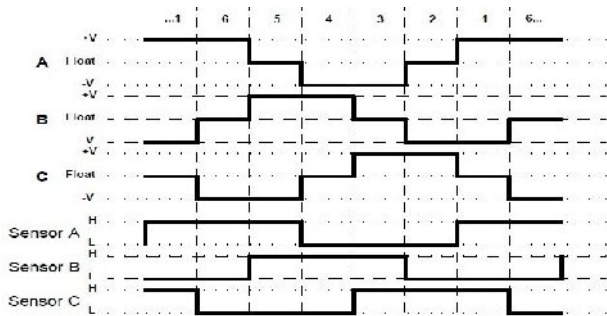

Fig.3. Back EMF and phase current variation with rotor electrical angle

The closed loop speed control of BLDC motor is achieved by the use of PID controller in association with GA optimization. The PID controller calculation algorithm involves three separate constant parameters, and is accordingly sometimes called three-term control: the

proportional, the integral and derivative values, denoted P,I, and D. Simply put, these values can be interpreted in terms of time. P depends on the present error, I on the accumulation of past errors, and D on the prediction of future errors, based on current rate of change. The weighted sum of these three actions is used to adjust the process via a control element such as the position of a control valve, a damper, or the power supplied to a heating element.

By tuning the three parameters in the PID controller algorithm, the controller can provide control action designed

for specific process requirements. The response of the controller can be described in terms of the responsiveness of the controller to an error, the degree to which the controller overshoots the set point, and the degree of system oscillation. Note that the use of the PID algorithm for control does not guarantee optimal control of the system or system stability.

The three types of controllers are combined together to form a PID controller. The PID controller is a device which produces an output signal, $u(t)$, consisting of three terms, one proportional to the input signal, $e(t)$, another one proportional to the integral of input signal, $e(t)$, and the third one proportional to the derivative of the input signal, $e(t)$. In PID controller;

$$u(t) = K_p e(t) + K_i \int e(t) dt + K_d \frac{d}{dt} e(t) \quad (4)$$

The transfer function of PID controller is given by equation (5).

$$G_{PID}(s) = \frac{K_p s + K_i + K_d s^2}{s} \quad (5)$$

As the PID controller has the combined effect of all the three control actions, the introduction of PID controller provides many advantages as it fuses the properties of P, PI and PD controller, it stabilizes the gain, reduces the steady state error, implementation costs are relatively cheap and are flexible, reduces the peak overshoot of the system and can work effectively with Genetic Algorithm optimization approach.

C. Genetic Algorithm

Genetic Algorithms (GA's) are a stochastic global search method that mimics the process of natural evolution. The genetic algorithm starts with no knowledge of the correct solution and depends entirely on responses from its environment and evolution operators to arrive at the best solution. By starting at several independent points and searching in parallel, the algorithm avoids local minima and converging to sub optimal solutions. In this way, GAs have been shown to be capable of locating high performance areas in complex domains without experiencing the difficulties associated with high dimensionality, as may occur with gradient decent techniques or methods that rely on derivative information.

A genetic algorithm is typically initialized with a random population consisting of between 20-100 individuals. This population (mating pool) is usually represented by a real-valued number or a binary string called a chromosome. How well an individual performs a task is measured is assessed by the objective function. The objective function assigns each individual a corresponding number called its fitness. The fitness of each chromosome is assessed and a survival of the fittest strategy is applied.

In this project, the magnitude of the error will be used to assess the fitness of each chromosome. There are three main stages of a genetic algorithm; these are known as reproduction, crossover and mutation. The steps involved in Genetic Algorithm are shown in the form of a flow chart in the fig.4 as shown below. It includes the processes of reproduction, crossover and mutation. By the fig.4, it shows the working of genetic algorithm in the proposed project. The parameter used here is the position of rotor of BLDC motor as given by the Hall Effect sensor.

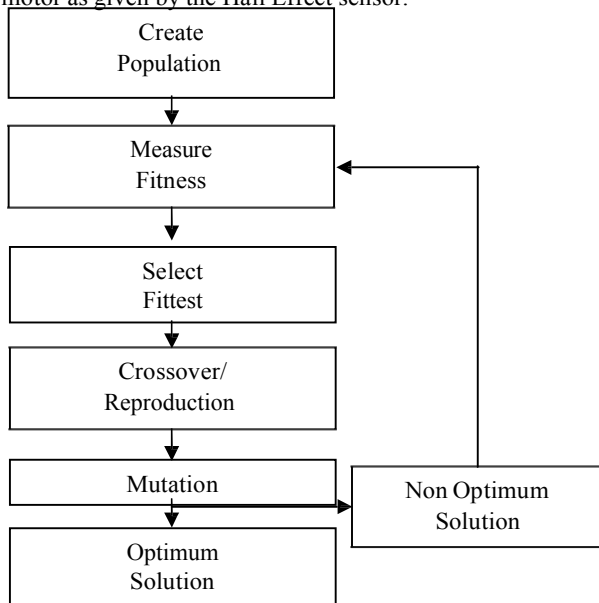

Fig.4. Flow chart of Genetic Algorithm process

The steps involved in creating and implementing a genetic algorithm are as follows:

1. Generate an initial, random population of individuals for a fixed size.
2. Evaluate their fitness.
3. Select the fittest members of the population.
4. Reproduce using a probabilistic method (e.g., Roulette wheel).
5. Implement crossover operation on the reproduced chromosomes (Choosing probabilistically both the crossover site and the 'Mates').
6. Execute mutation operation with low probability.
7. Repeat step 2 until a predefined convergence criterion is met.

The convergence criterion of a genetic algorithm is a user-specified condition e.g. the maximum number of generations and here the rated speed of the BLDC motor is specified as 500 rpm. The GA optimized PID controller provides the necessary reference signal for Space Vector PWM technique to the driver circuit

D. Space Vector Pulse Width Modulation

Space Vector Pulse Width Modulation (SVPWM) is an algorithm which is developed for the control of Pulse Width Modulation (PWM). It is used for the creation of Alternating Current (AC) waveforms; most commonly to drive 3 phase AC powered motors at varying speeds from DC using multiple class-D amplifiers. There are various variations of SVPWM that result in different quality and computational requirements. One active area of development is in the reduction of total harmonic distortion (THD) created by the rapid switching inherent to these algorithms.

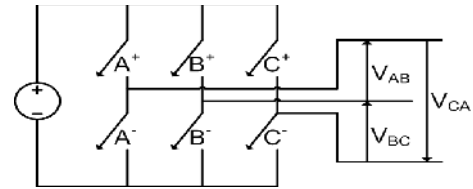

Fig.5. A basic three phase inverter.

A three phase inverter as shown in fig.5 must be controlled so that at no time both switches in the same leg are turned on or else the DC supply would be shorted. This requirement may be met by the complementary operation of the switches within a leg. i.e.; if A^+ is on, then A^- is off and vice versa. This leads to eight possible switching vectors for the inverter, V_0 through V_7 with six active switching vectors and two zero vectors as shown in the vector diagram in the Figure 3.3.

To implement space vector modulation a reference signal V_{ref} is sampled with a frequency, f_s ($T_s = 1/f_s$). The reference signal in this project is generated from the GA optimized PID controller. The reference vector is then synthesized using a combination of the two adjacent active switching vectors and one or both of the zero vectors.

III. SIMULATION RESULTS

The simulation of the four quadrant operation of BLDC Motor in association with GA optimized PID controller and Space Vector PWM method is done by using MatLab/Simulink. The various input and output waveforms obtained for the forward motoring mode operation are showed below. The input voltage of 110v is fed to the inverter and three phase voltage output is given to the BLDC motor. Here the various outputs are shown with respect to the time. The operation of BLDC Motor in four operating

modes by the use of GA optimized PID controller in association with Space Vector PWM algorithm can be clearly known from the below showed figures [fig.5 (a-e)]. The output speed of BLDC Motor is found to be controlled at a constant speed of 500 rpm after a sudden rise and fall of speed at the time of starting the motor. The THD of the inverter output is found

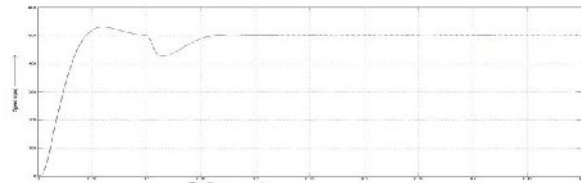
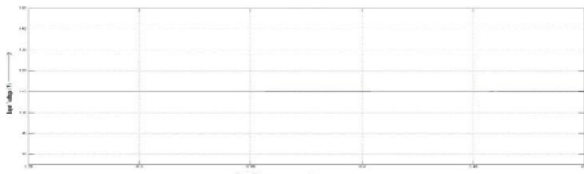
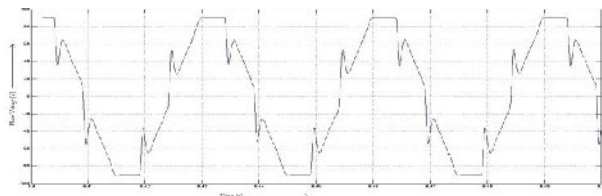

Fig.5(a). Output speed.



(b) Input voltage V_{in} .



(c) Phase voltage V_{in} .

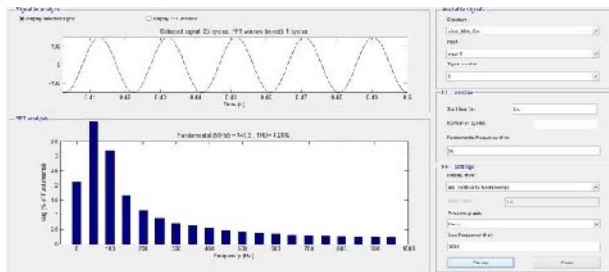

(d) Total Harmonic Distortion of inverter output.

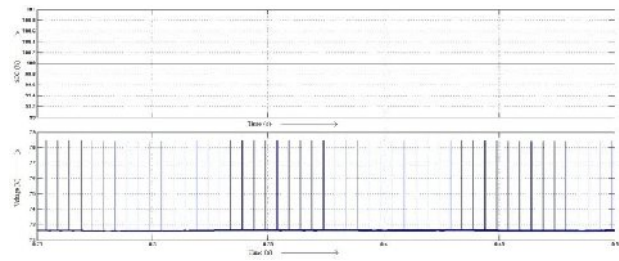

(e) Regenerative output connected to the Battery.

to be 4.26% for one cycle of operation. The regenerative output given to the battery is found to be 72.5v and state of charge is 100%, which decreases the losses in the system.

IV. CONCLUSION

This paper deals with the four quadrant speed control of the BLDC Motor by position control of the stator winding excitation is presented. It included the closed loop control with the help of GA optimized PID controller and Space Vector PWM applied to the gate driver circuit of the inverter supplying power to the BRUSHLESS DC Motor. The simulation results include the performance of Space Vector PWM technique. However PID controller works more effectively when GA is optimized with PID controller. Hence it can be concluded that GA and SVPWM provides an efficient controller tuning methodology for obtaining improved and accurate performance of the system.

V. REFERENCES

- [1] C. Sheeba Joice, S. R. Paranjothi, and V. Jawahar Senthil Kumar, "Digital Control Strategy for Four Quadrant Operation of Three Phase BLDC Motor With Load Variations" - *IEEE Trans. on Industrial Informatics*, vol. 9, no. 2, May 2013.
- [2] Bhim Singh and Sanjeev Singh, "State of the art on Permanent Magnet Brushless DC Motor Drives" - *Journal of Power Electronics*, Vol. 9, No. 1, January 2009.
- [3] Francis Bofo Effah, Patrick Wheeler, Jon Clare and Alan Watson, "Space-Vector-Modulated Three-Level Inverters With a Single Z-Source Network" - *IEEE Trans. on Power Electronics*, vol. 28, no. 6, June 2013.
- [4] Alin , Stirban, Ion Boldea and Gheorghe-Daniel Andreescu, "Motion-Sensorless Control of BLDC-PM Motor With Offline FEM-Information-Assisted Position and Speed Observer" - *IEEE Trans. on Industry Applications*, vol. 48, no. 6, November/December 2012.
- [5] Anand Sathyan, Nikola Milivojevic, Young-Joo Lee, Mahesh Krishnamurthy and Ali Emadi, "An FPGA-Based Novel Digital PWM Control Scheme for BLDC Motor

Drives” - *IEEE Trans. on Industrial Electronics*, vol. 56, no. 8, August 2009.

[6] Changliang Xia, Zhiqiang Li, and Tingna Shi, “A control strategy for four-switch three-phase brushless DC motor using single current sensor” -*IEEE Trans. On Industrial Electronics*, vol. 56, no. 6, June 2009.

[7] E. Afjei, O. Hashemipour, M. A. Saati and M. M. Nezamabadi, “A new hybrid brushless DC motor/generator without permanent magnet”- *IJE Transactions B: Applications Vol. 20, No. 1, April 2007*.

[8] Chung-Wen Hung, Cheng-Tsung Lin, Chih-Wen Liu and Jia-Yush Yen, “A Variable-Sampling Controller for Brushless DCMotor Drives With Low-Resolution Position Sensors”-*IEEE Trans. on Industrial Electronics*, vol. 54, no. 5, October 2007.